

CZT2907A
SURFACE MOUNT
PNP SILICON TRANSISTOR

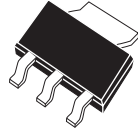

SOT-223 CASE

CentralTM

Semiconductor Corp.

DESCRIPTION:

The CENTRAL SEMICONDUCTOR CZT2907A type is a PNP silicon transistor manufactured by the epitaxial planar process, epoxy molded in a surface mount package, designed for general purpose amplifier and switching applications.

MARKING CODE: FULL PART NUMBER

MAXIMUM RATINGS: ($T_A=25^\circ\text{C}$)

	SYMBOL		UNITS
Collector-Base Voltage	V_{CBO}	60	V
Collector-Emitter Voltage	V_{CEO}	60	V
Emitter-Base Voltage	V_{EBO}	5.0	V
Collector Current	I_C	600	mA
Power Dissipation	P_D	2.0	W
Operating and Storage			
Junction Temperature	T_J, T_{stg}	-65 to +150	$^\circ\text{C}$
Thermal Resistance	θ_{JA}	62.5	$^\circ\text{C/W}$

ELECTRICAL CHARACTERISTICS: ($T_A=25^\circ\text{C}$ unless otherwise noted)

SYMBOL	TEST CONDITIONS	MIN	MAX	UNITS
I_{CBO}	$V_{CB}=50\text{V}$		10	nA
I_{CBO}	$V_{CB}=50\text{V}, T_A=125^\circ\text{C}$		10	μA
I_{CEV}	$V_{CE}=30\text{V}, V_{BE}=0.5\text{V}$		50	nA
BV_{CBO}	$I_C=10\mu\text{A}$	60		V
BV_{CEO}	$I_C=10\text{mA}$	60		V
BV_{EBO}	$I_E=10\mu\text{A}$	5.0		V
$V_{CE(SAT)}$	$I_C=150\text{mA}, I_B=15\text{mA}$		0.4	V
$V_{CE(SAT)}$	$I_C=500\text{mA}, I_B=50\text{mA}$		1.6	V
$V_{BE(SAT)}$	$I_C=150\text{mA}, I_B=15\text{mA}$		1.3	V
$V_{BE(SAT)}$	$I_C=500\text{mA}, I_B=50\text{mA}$		2.6	V
h_{FE}	$V_{CE}=10\text{V}, I_C=0.1\text{mA}$	75		
h_{FE}	$V_{CE}=10\text{V}, I_C=1.0\text{mA}$	100		
h_{FE}	$V_{CE}=10\text{V}, I_C=10\text{mA}$	100		
h_{FE}	$V_{CE}=10\text{V}, I_C=150\text{mA}$	100	300	
h_{FE}	$V_{CE}=10\text{V}, I_C=500\text{mA}$	50		

**SURFACE MOUNT
PNP SILICON TRANSISTOR**

ELECTRICAL CHARACTERISTICS: ($T_A=25^\circ\text{C}$ unless otherwise noted)

SYMBOL	TEST CONDITIONS	MIN	MAX	UNITS
f_T	$V_{CE}=20\text{V}$, $I_C=50\text{mA}$, $f=100\text{MHz}$	200		MHz
C_{ob}	$V_{CB}=10\text{V}$, $I_E=0$, $f=1.0\text{MHz}$		8.0	pF
C_{ib}	$V_{BE}=2.0\text{V}$, $I_C=0$, $f=1.0\text{MHz}$		30	pF
t_{on}	$V_{CC}=30\text{V}$, $V_{BE}=0.5\text{V}$, $I_C=150\text{mA}$, $I_{B1}=15\text{mA}$		45	ns
t_d	$V_{CC}=30\text{V}$, $V_{BE}=0.5\text{V}$, $I_C=150\text{mA}$, $I_{B1}=15\text{mA}$		10	ns
t_r	$V_{CC}=30\text{V}$, $V_{BE}=0.5\text{V}$, $I_C=150\text{mA}$, $I_{B1}=15\text{mA}$		40	ns
t_{off}	$V_{CC}=6.0\text{V}$, $I_C=150\text{mA}$, $I_{B1}=I_{B2}=15\text{mA}$		100	ns
t_s	$V_{CC}=6.0\text{V}$, $I_C=150\text{mA}$, $I_{B1}=I_{B2}=15\text{mA}$		80	ns
t_f	$V_{CC}=6.0\text{V}$, $I_C=150\text{mA}$, $I_{B1}=I_{B2}=15\text{mA}$		30	ns

SOT-223 CASE - MECHANICAL OUTLINE

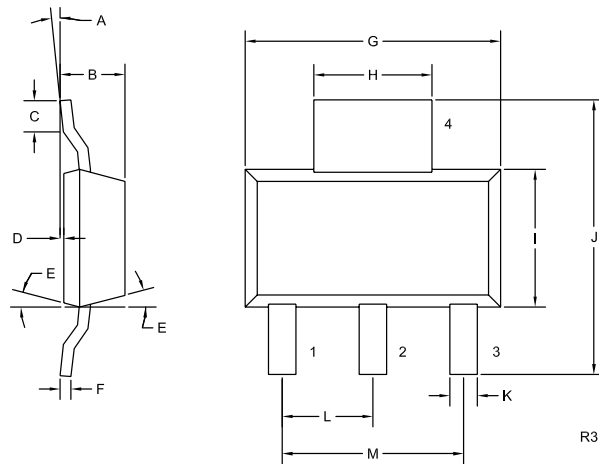

LEAD CODE:

- 1) BASE
- 2) COLLECTOR
- 3) EMITTER
- 4) COLLECTOR

**MARKING CODE:
FULL PART NUMBER**

SYMBOL	DIMENSIONS			
	INCHES		MILLIMETERS	
	MIN	MAX	MIN	MAX
A	0°	10°	0°	10°
B	0.059	0.071	1.50	1.80
C	0.018	---	0.45	---
D	0.000	0.004	0.00	0.10
E	15°		15°	
F	0.009	0.014	0.23	0.35
G	0.248	0.264	6.30	6.70
H	0.114	0.122	2.90	3.10
I	0.130	0.146	3.30	3.70
J	0.264	0.287	6.70	7.30
K	0.024	0.033	0.60	0.85
L	0.091		2.30	
M	0.181		4.60	

SOT-223 (REV: R3)

R4 (17-June 2004)